

Name _____ Date _____

1. John tiled some rectangles using square units. Sketch the rectangles if necessary. Fill in the missing information, and then confirm the area by multiplying.

a. Rectangle A:

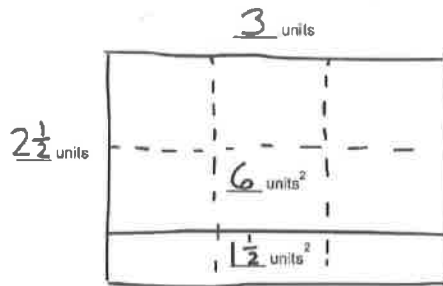

Rectangle A is

3 units long $2\frac{1}{2}$ units wide

Area = _____ units²

b. Rectangle B:

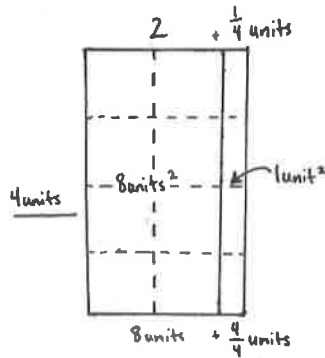

Rectangle B is

_____ units long _____ units wide

Area = _____ units²

c. Rectangle C:

Rectangle C is

$\frac{3}{4}$ units long 4 units wide

Area = _____ units²

d. Rectangle D:

Rectangle D is

2 units long $1\frac{3}{4}$ units wide

Area = _____ units²

2. Rachel made a mosaic from different color rectangular tiles. Three tiles measured $3\frac{1}{2}$ inches \times 3 inches. Six tiles measured 4 inches \times $3\frac{1}{4}$ inches. What is the area of the whole mosaic in square inches?

3. A garden box has a perimeter of $27\frac{1}{2}$ feet. If the length is 9 feet, what is the area of the garden box?

Name _____

Date _____

1. Kristen tiled the following rectangles using square units. Sketch the rectangles, and find the areas. Then, confirm the area by multiplying. Rectangle A has been sketched for you.

- a. Rectangle A:

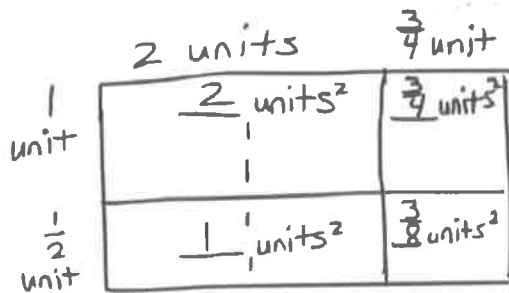

Rectangle A is

_____ units long \times _____ units wide

Area = _____ units²

- b. Rectangle B:

Rectangle B is

$2\frac{1}{2}$ units long \times $\frac{3}{4}$ unit wide

Area = _____ units²

- c. Rectangle C:

Rectangle C is

$3\frac{1}{3}$ units long \times $2\frac{1}{2}$ units wide

Area = _____ units²

d. Rectangle D:

Rectangle D is

$3\frac{1}{2}$ units long \times $2\frac{1}{4}$ units wide

Area = _____ units²

2. A square has a perimeter of 25 inches. What is the area of the square?

Name _____

Date _____

1. Measure each rectangle to the nearest $\frac{1}{4}$ inch with your ruler, and label the dimensions. Use the area model to find the area.

a.

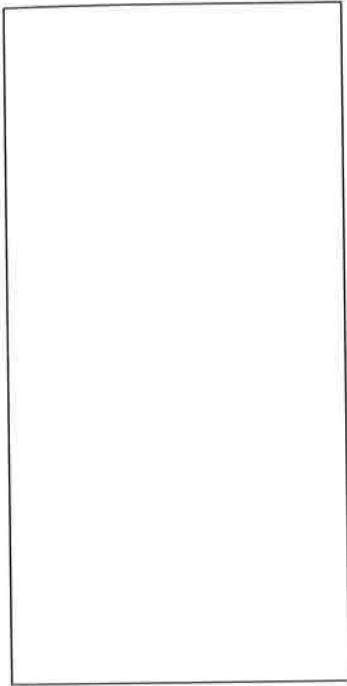

b.



c.

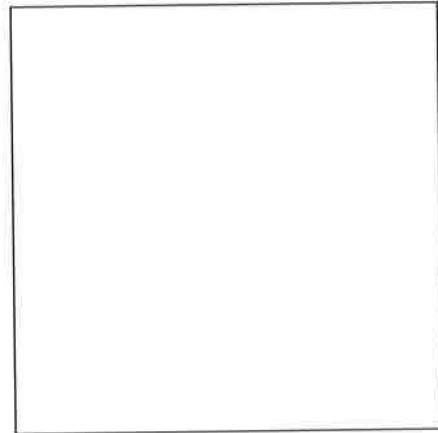

d.

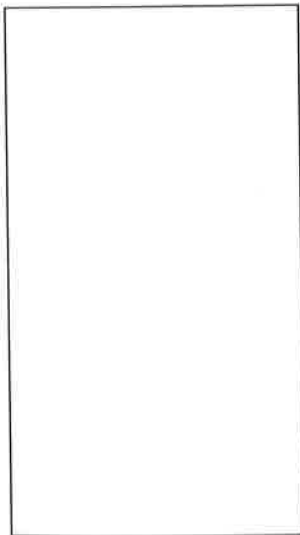

e.



2. Find the area of rectangles with the following dimensions. Explain your thinking using the area model.

a. $2\frac{1}{4}$ yd \times $\frac{1}{4}$ yd

b. $2\frac{1}{2}$ ft \times $1\frac{1}{4}$ ft

3. Kelly buys a tarp to cover the area under her tent. The tent is 4 feet wide and has an area of 31 square feet. The tarp she bought is $5\frac{1}{3}$ feet by $5\frac{3}{4}$ feet. Can the tarp cover the area under Kelly's tent? Draw a model to show your thinking.

4. Shannon and Leslie want to carpet a $16\frac{1}{2}$ -ft by $16\frac{1}{2}$ -ft square room. They cannot put carpet under an entertainment system that juts out. (See the drawing below.)

- a. In square feet, what is the area of the space with no carpet?

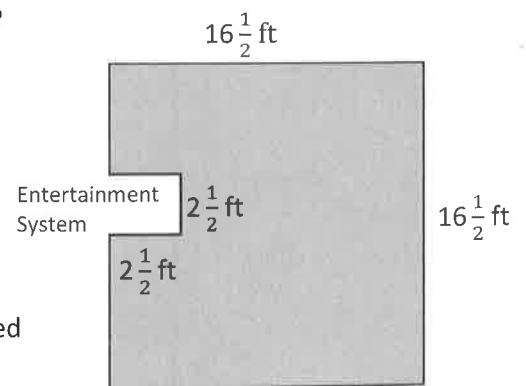

- b. How many square feet of carpet will Shannon and Leslie need to buy?

Name _____

Date _____

1. Find the area of the following rectangles. Draw an area model if it helps you.

a. $\frac{8}{3} \text{ cm} \times \frac{24}{4} \text{ cm}$

b. $\frac{32}{5} \text{ ft} \times 3\frac{3}{8} \text{ ft}$

c. $5\frac{4}{6} \text{ in} \times 4\frac{3}{5} \text{ in}$

d. $\frac{5}{7} \text{ m} \times 6\frac{3}{5} \text{ m}$

2. Chris is making a tabletop from some leftover tiles. He has 9 tiles that measure $3\frac{1}{8}$ inches long and $2\frac{3}{4}$ inches wide. What is the greatest area he can cover with these tiles?

3. A hotel is recarpeting a section of the lobby. Carpet covers the part of the floor as shown below in gray. How many square feet of carpeting will be needed?

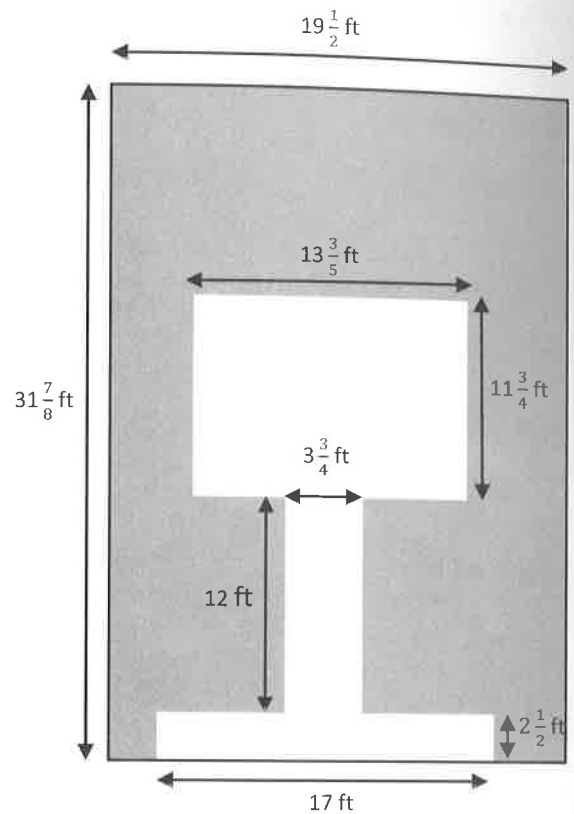

Name _____

Date _____

1. Mr. Albano wants to paint menus on the wall of his café in chalkboard paint. The gray area below shows where the rectangular menus will be. Each menu will measure 6-ft wide and $7\frac{1}{2}$ -ft tall.

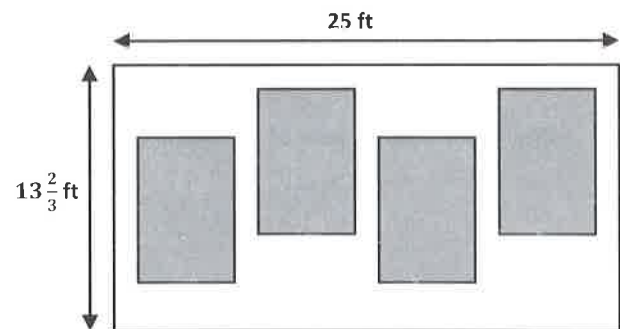

- How many square feet of menu space will Mr. Albano have?

 - What is the area of wall space that is not covered by chalkboard paint?
2. Mr. Albano wants to put tiles in the shape of a dinosaur at the front entrance. He will need to cut some tiles in half to make the figure. If each square tile is $4\frac{1}{4}$ inches on each side, what is the total area of the dinosaur?

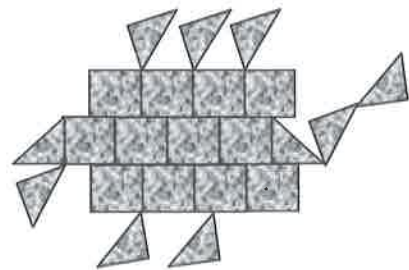

Name _____

Date _____

1. The width of a picnic table is 3 times its length. If the length is $\frac{5}{6}$ -yd long, what is the area of the picnic table in square feet?

2. A painting company will paint this wall of a building. The owner gives them the following dimensions:

Window A is $6\frac{1}{4}$ ft \times $5\frac{3}{4}$ ft.

Window B is $3\frac{1}{8}$ ft \times 4 ft.

Window C is $9\frac{1}{2}$ ft².

Door D is 4 ft \times 8 ft.

What is the area of the painted part of the wall?

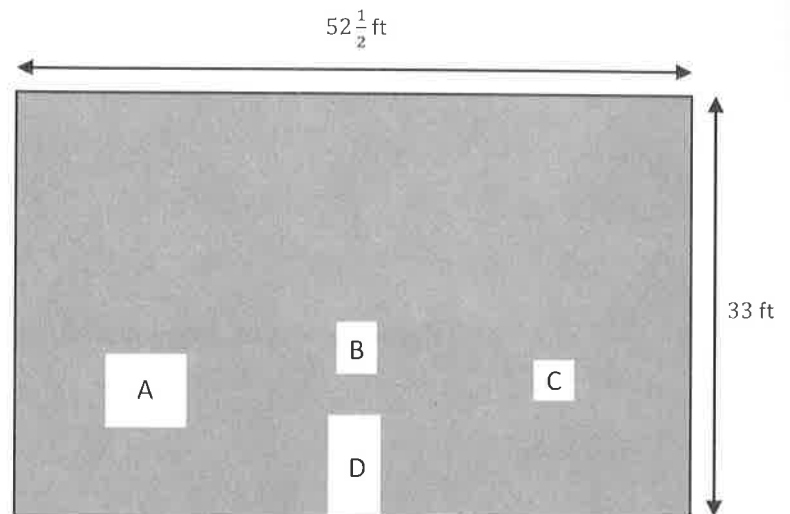

3. A decorative wooden piece is made up of four rectangles as shown to the right. The smallest rectangle measures $4\frac{1}{2}$ inches by $7\frac{3}{4}$ inches. If $2\frac{1}{4}$ inches are added to each dimension as the rectangles get larger, what is the total area of the entire piece?

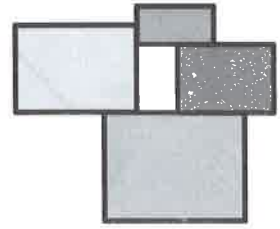

Name _____

Date _____

1. Use a straightedge and the grid paper to draw:

a. A trapezoid with exactly 2 right angles.

b. A trapezoid with no right angles.

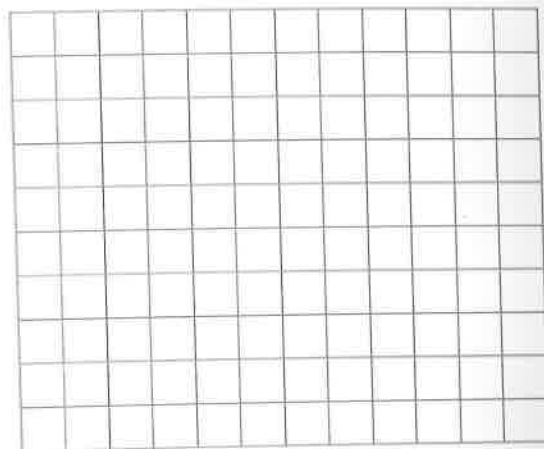
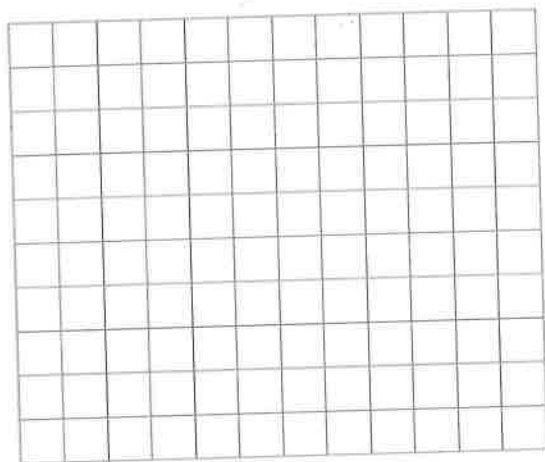

2. Kaplan incorrectly sorted some quadrilaterals into trapezoids and non-trapezoids as pictured below.

a. Circle the shapes that are in the wrong group, and tell why they are sorted incorrectly.

Trapezoids	Non-Trapezoids

b. Explain what tools would be necessary to use to verify the placement of all the trapezoids.

3. a. Use a straightedge to draw an isosceles trapezoid on the grid paper.

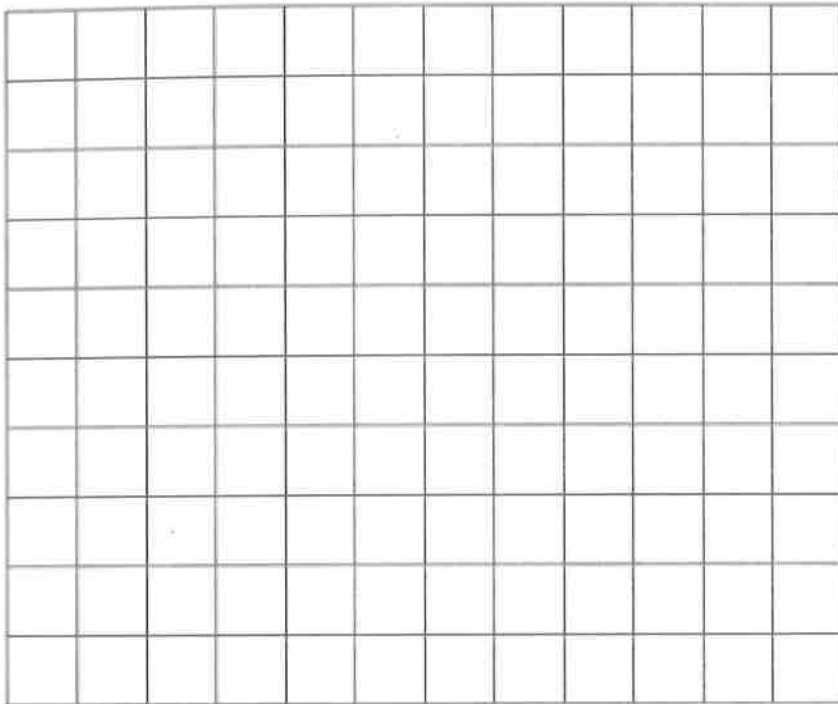

- b. Why is this shape called an isosceles trapezoid?

Name _____

Date _____

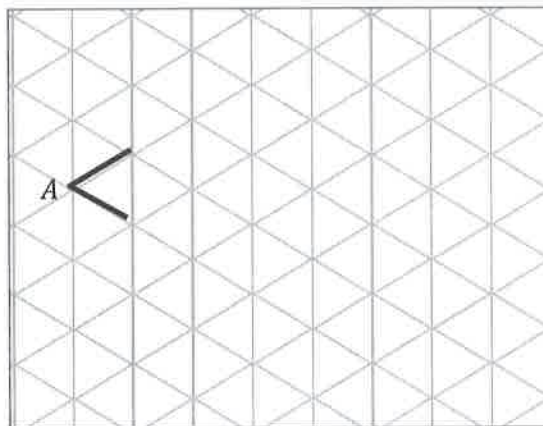
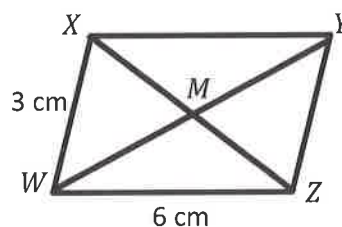
1. $\angle A$ measures 60° .a. Extend the rays of $\angle A$, and draw parallelogram $ABCD$ on the grid paper.b. What are the measures of $\angle B$, $\angle C$, and $\angle D$?2. $WXYZ$ is a parallelogram not drawn to scale.a. Using what you know about parallelograms, give the measure of sides XY and YZ .b. $\angle WXY = 113^\circ$. Use what you know about angles in a parallelogram to find the measure of the other angles.

$\angle XYZ = \underline{\hspace{2cm}}^\circ$

$\angle YZW = \underline{\hspace{2cm}}^\circ$

$\angle ZWX = \underline{\hspace{2cm}}^\circ$

3. Jack measured some segments in Problem 2. He found that $\overline{WY} = 8$ cm and $\overline{MZ} = 3$ cm.

Give the lengths of the following segments:

$WM = \underline{\hspace{2cm}}$ cm

$MY = \underline{\hspace{2cm}}$ cm

$XM = \underline{\hspace{2cm}}$ cm

$XZ = \underline{\hspace{2cm}}$ cm

Name _____

Date _____

1. Draw a parallelogram.

2. When is a trapezoid also called a parallelogram?

Name _____

Date _____

1. Use the grid paper to draw.

a. A rhombus with no right angles

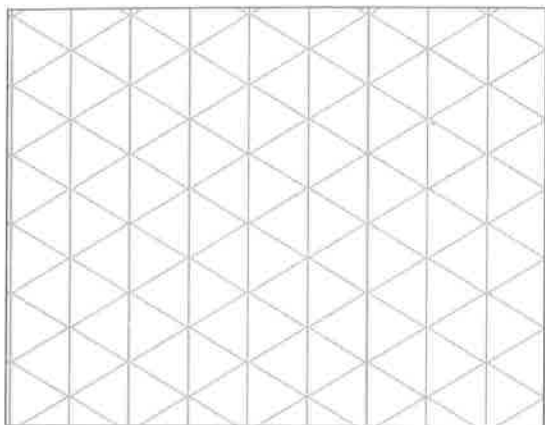

b. A rhombus with 4 right angles

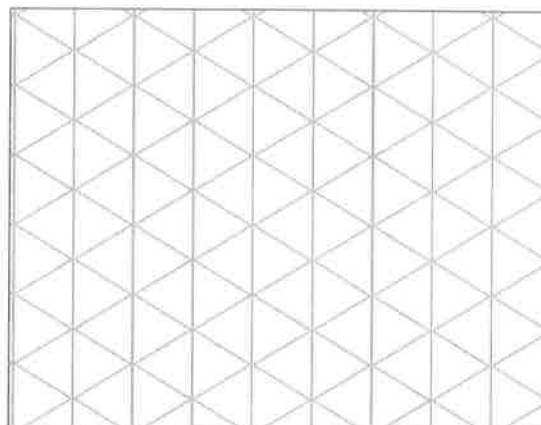

c. A rectangle with not all sides equal

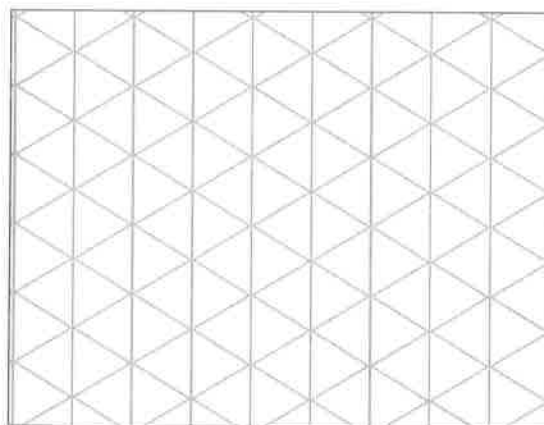

d. A rectangle with all sides equal

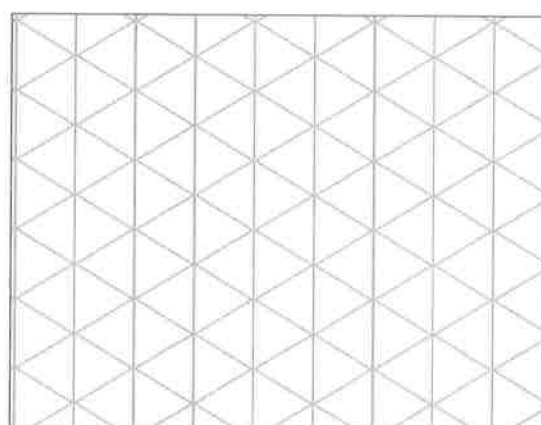

2. A rhombus has a perimeter of 217 cm. What is the length of each side of the rhombus?

3. List the properties that all rhombuses share.

4. List the properties that all rectangles share.

Name _____

Date _____

1. a. Draw a kite that is not a parallelogram on the grid paper,

- b. List all the properties of a kite.

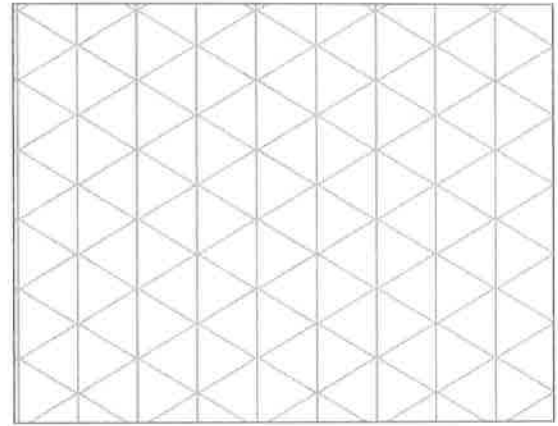

- c. When can a parallelogram also be a kite?

2. If rectangles must have right angles, explain how a rhombus could also be called a rectangle.

3. Draw a rhombus that is also a rectangle on the grid paper.

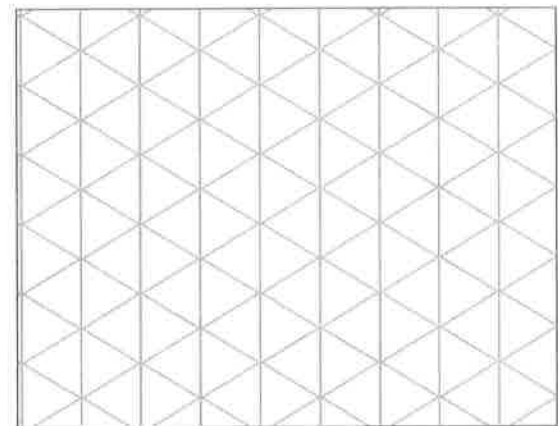

4. Kirkland says that figure $EFGH$ below is a quadrilateral because it has four points in the same plane and four segments with no three endpoints collinear. Explain his error.



Name _____

Date _____

1. Follow the flow chart, and put the name of the figure in the boxes.

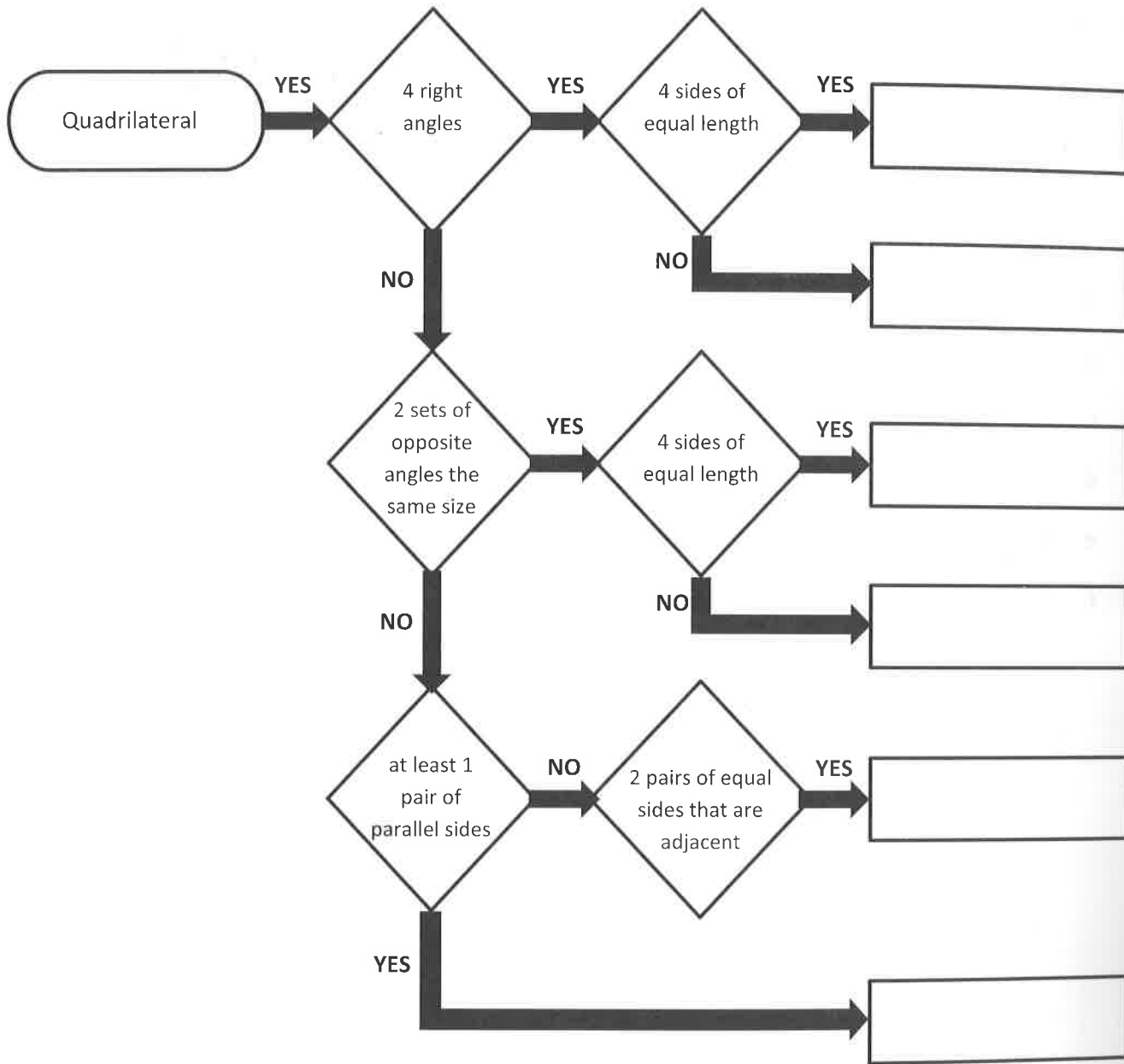

2. $SQRE$ is a square with an area of 49 cm^2 , and $RM = 4.95 \text{ cm}$. Find the measurements using what you know about the properties of squares.

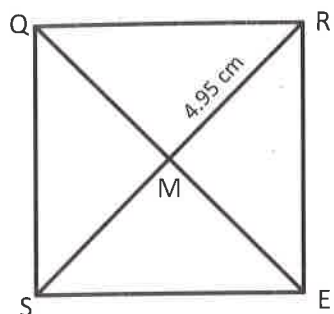

- a. $RS =$ _____ cm
b. $QE =$ _____ cm
c. Perimeter = _____ cm
d. $m\angle QRE =$ _____ $^\circ$
e. $m\angle RMQ =$ _____ $^\circ$

Name _____

Date _____

1. Answer the questions by checking the box.

Sometimes

Always

- a. Is a square a rectangle?
 b. Is a rectangle a kite?
 c. Is a rectangle a parallelogram?
 d. Is a square a trapezoid?
 e. Is a parallelogram a trapezoid?
 f. Is a trapezoid a parallelogram?
 g. Is a kite a parallelogram?

Sometimes	Always

- h. For each statement that you answered with *sometimes*, draw and label an example that justifies your answer.

2. Use what you know about quadrilaterals to answer each question below.

- a. Explain when a trapezoid is not a parallelogram. Sketch an example.
- b. Explain when a kite is not a parallelogram. Sketch an example.

Name _____

Date _____

1. Each rectangular prism is built from centimeter cubes. State the dimensions, and find the volume.

a.

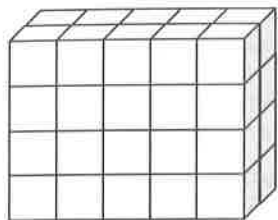

Length: _____ cm

Width: _____ cm

Height: _____ cm

Volume: _____ cm^3

b.

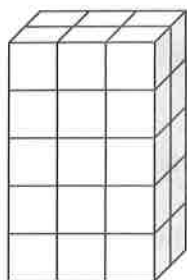

Length: _____ cm

Width: _____ cm

Height: _____ cm

Volume: _____ cm^3

c.

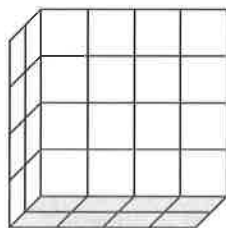

Length: _____ cm

Width: _____ cm

Height: _____ cm

Volume: _____ cm^3

d.

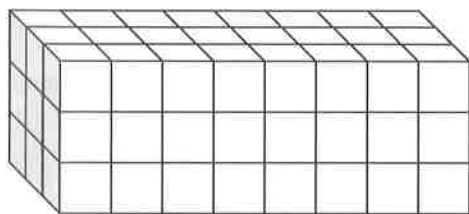

Length: _____ cm

Width: _____ cm

Height: _____ cm

Volume: _____ cm^3

2. Write a multiplication sentence that you could use to calculate the volume for each rectangular prism in Problem 1. Include the units in your sentences.

a. _____

b. _____

c. _____

d. _____

3. Calculate the volume of each rectangular prism. Include the units in your number sentences.

a.

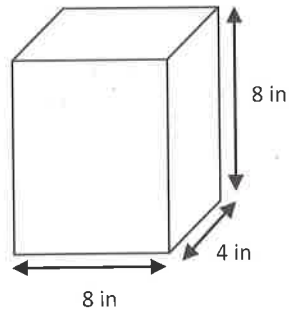

Volume: _____

b.

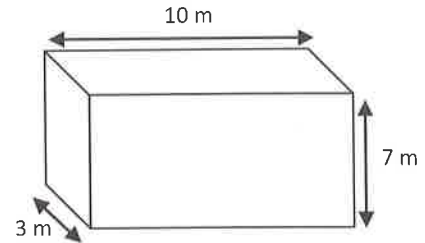

Volume: _____

4. Mrs. Johnson is constructing a box in the shape of a rectangular prism to store clothes for the summer. It has a length of 28 inches, a width of 24 inches, and a height of 30 inches. What is the volume of the box?

5. Calculate the volume of each rectangular prism using the information that is provided.

a. Face area: 56 square meters

Height: 4 meters

b. Face area: 169 square inches

Height: 14 inches

Name _____

Date _____

1. Johnny filled a container with 30 centimeter cubes. Shade the beaker to show how much water the container will hold. Explain how you know.

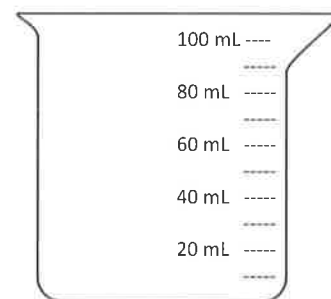

2. A beaker contains 250 mL of water. Jack wants to pour the water into a container that will hold the water. Which of the containers pictured below could he use? Explain your choices.

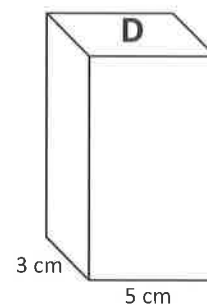
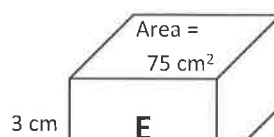
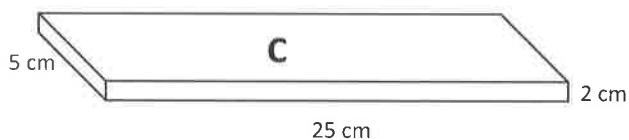
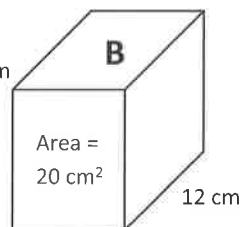
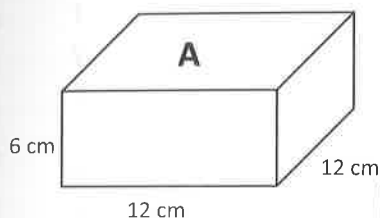

3. On the back of this paper, describe the details of the activities you did in class today. Include what you learned about cubic centimeters and milliliters. Give an example of a problem you solved with an illustration.

Name _____

Date _____

1. Find the total volume of the figures, and record your solution strategy.

a.

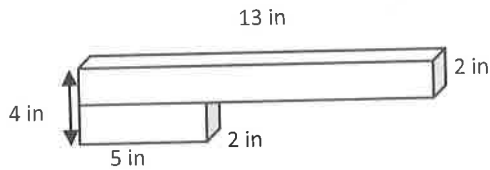

Volume: _____

Solution Strategy:

b.

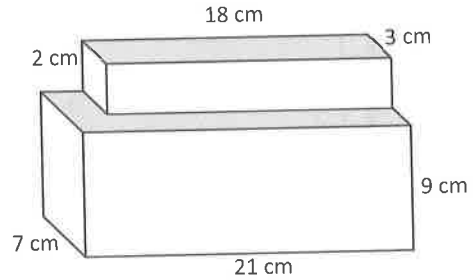

Volume: _____

Solution Strategy:

c.

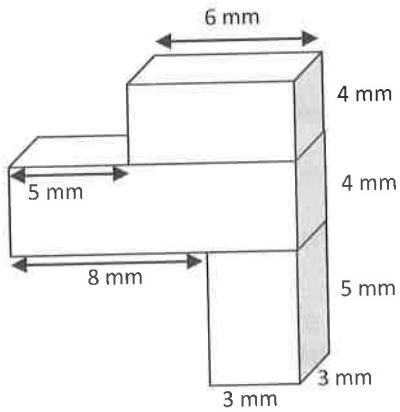

Volume: _____

Solution Strategy:

d.

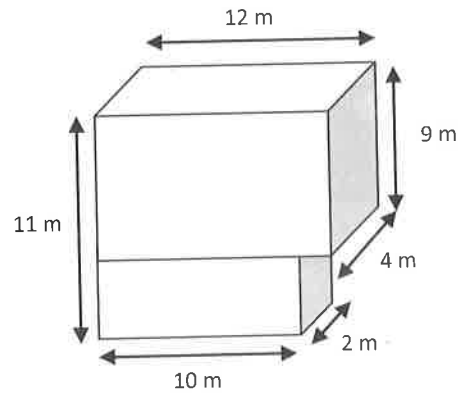

Volume: _____

Solution Strategy:

2. The figure below is made of two sizes of rectangular prisms. One type of prism measures 3 inches by 6 inches by 14 inches. The other type measures 15 inches by 5 inches by 10 inches. What is the total volume of this figure?

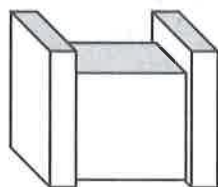

3. The combined volume of two identical cubes is 250 cubic centimeters. What is the measure of one cube's edge?
4. A fish tank has a base area of 45 cm^2 and is filled with water to a depth of 12 cm. If the height of the tank is 25 cm, how much more water will be needed to fill the tank to the brim?

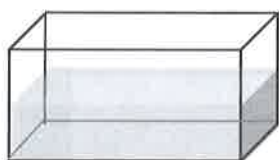

5. Three rectangular prisms have a combined volume of 518 cubic feet. Prism A has one-third the volume of Prism B, and Prisms B and C have equal volume. What is the volume of each prism?

3. Wren wants to build a box to organize her scrapbook supplies. She has a stencil set that is 12 inches wide that needs to lay flat in the bottom of the box. The supply box must also be no taller than 2 inches. Name one way she could build a supply box with a volume of 72 cubic inches.
4. After all of this organizing, Wren decides she also needs more storage for her soccer equipment. Her current storage box measures 1 foot long by 2 feet wide by 2 feet high. She realizes she needs to replace it with a box with 12 cubic feet of storage, so she doubles the width.
- Will she achieve her goal if she does this? Why or why not?
 - If she wants to keep the height the same, what could the other dimensions be for a 12-cubic-foot storage box?
 - If she uses the dimensions in part (b), what is the area of the new storage box's floor?
 - How has the area of the bottom in her new storage box changed? Explain how you know.

Name _____

Date _____

1. I have a prism with the dimensions of 6 cm by 12 cm by 15 cm. Calculate the volume of the prism, and then give the dimensions of three different prisms that each have $\frac{1}{3}$ of the volume.

	Length	Width	Height	Volume
Original Prism	6 cm	12 cm	15 cm	
Prism 1				
Prism 2				
Prism 3				

2. Sunni's bedroom has the dimensions of 11 ft by 10 ft by 10 ft. Her den has the same height but double the volume. Give two sets of the possible dimensions of the den and the volume of the den.